

RELENTLESS PERFORMANCE

Embrace the challenge with unstoppable
power and endurance

Pro 6025T

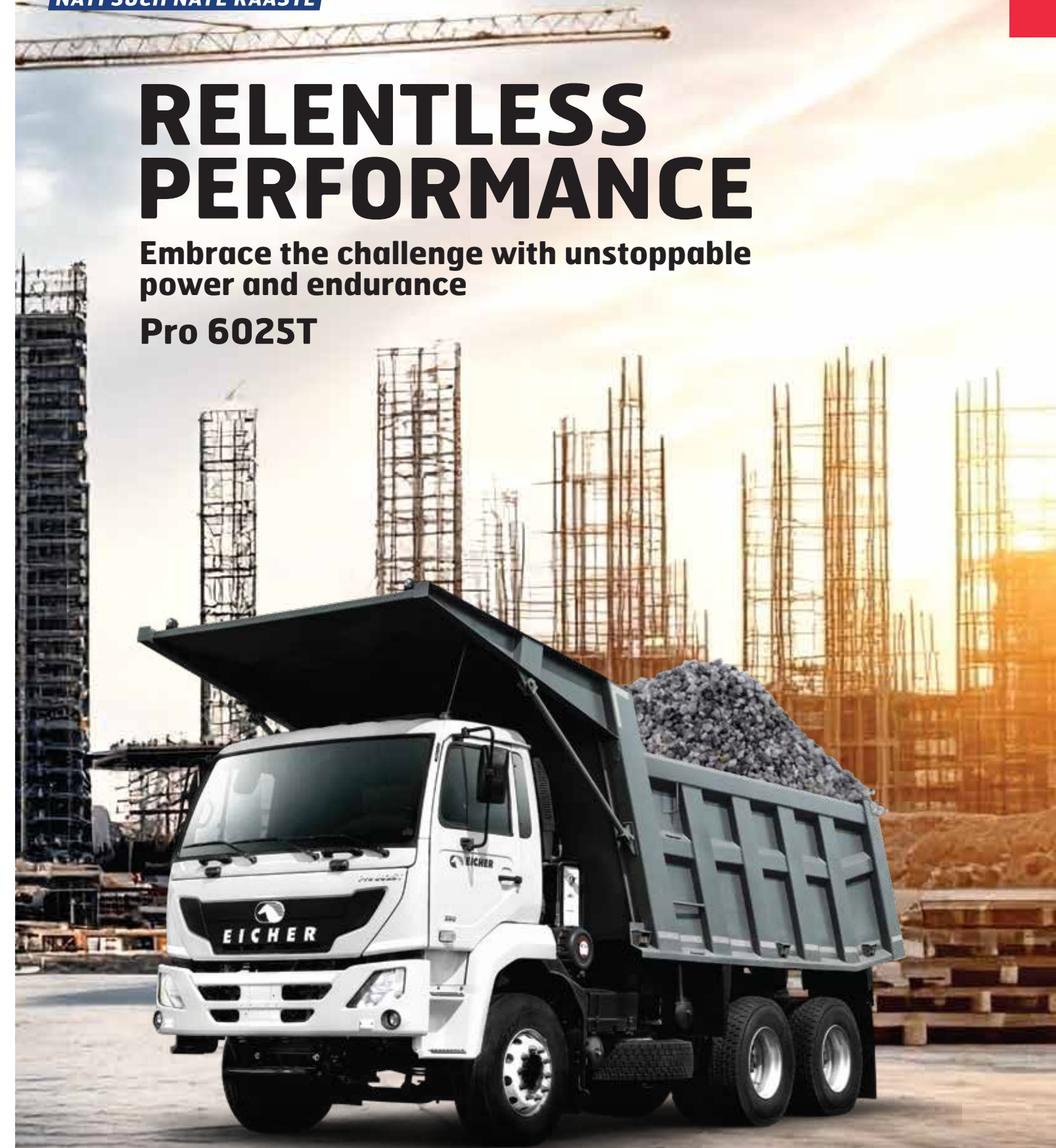

EICHER TRUCKS AND BUSES

VE Commercial Vehicles Ltd.
(A Volvo Group and Eicher Motors joint venture)
#96, Institutional Area, 3rd Floor, Sector 32,
Gurgaon, Haryana - 122001, India.
Phone: +91 0124-4415600
www.eichertrucksandbuses.com

AUTHORIZED DISTRIBUTOR

Powered by
EUTECH 5

PARTNERING PROSPERITY

Two leading players in the commercial vehicle business joined hands in 2008 with a convergent vision of driving modernization in commercial transportation. Volvo Group, the world's leading manufacturer of trucks, buses, construction equipment and marine and industrial engines, has infused its global expertise and world-class technology, with Eicher Motors' innovative engineering and proven DNA of fuel efficiency.

VECV includes the complete range of Eicher commercial vehicles, components and engineering design businesses as well as the sales and distribution of Volvo trucks in India. Each of its business units is well-established and backed by a sizable customer base.



- Best-in-class fuel efficiency
- Frugal engineering & operations
- Indian leader in medium-duty trucks
- Strong aftersales support



- Environment & safety conscious
- World-class technology
- Global leaders in heavy-duty trucks
- Customer-driven solutions



EICHER'S EURO-V STORY

Eicher is creating a new benchmark in the commercial vehicle industry with a revolutionary Euro V solution that combines global technology with innovative support services. This solution doesn't just make your vehicle Euro V compliant but ensures higher productivity of the truck and profitability of your business.



Euro V expertise

VECV has been manufacturing & supplying Euro V engines to Volvo Group since 2018. The engine has been tested for more than 10,00,000 Kms

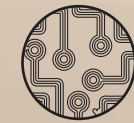

Superior Uptime

With the new Euro V technology, superior uptime means that not only the passengers reach their destination on time, but the buses are raring to go for their next trips, and profits are being made on each trip



Efficient EATS and Engine Technology

With the improved Euro V technology, Our EATS system will now treat and control pollutants like NOx, CO, HC and PM more efficiently, through different chemical processes



Superior Reliability and Durability

With the Euro V technology, our trucks are equipped with superior Reliability with stronger and improved aggregates.



DO MORE WITH EICHER PRO 6025T

The new Eicher Pro 6025T is the next generation 25 tonne GVW Tipper. With the power of 330HP and higher Torque Output of 1200Nm the Eicher Pro 6025T is designed to deliver Relentless Performance



Relentless
Performance



Superior
Uptime



More Comfort & Safety
with Enhanced Comfort & Safert



• Superior Uptime

In any Segment Uptime is everything and Pro 6025T is designed to ensure optimum utilization of all the assets. Pro 6025T delivers superior uptime ensuring that operations never stop.

- ET140S9 9 speed gearbox
- Bogie Suspension
- VECV Rear Axle



• Relentless Performance

The new Eicher Pro 6025T is equipped with world class Volvo VDEX8 Engine. The VDEX8 engine clubbed with Volvo Group's EMS, delivers high peak torque over a wide range of RPM, ensuring relentless performance

- Volvo VDEX8 Engine
- Volvo Group EMS



• Enhanced Comfort and Safety

The Pro 6025T cabin has been designed keeping in mind the harsh conditions that drivers have to face. This Global standard cabin provides a comfortable and safe workspace that ensures maximum driver efficiency.

- Volvo Engine Protection System
- Advanced On Board Diagnostics
- Air Filter Restriction Indicator
- Intelligent Driver Information System



TECHNICAL SPECIFICATIONS

Pro 6025T Euro-5 Vehicle specification

Model	Pro 6025T	Pro 6025T	Pro 6025T	Pro 6025TM
Variants	CBC	16 CuM BB	14 CuM RB	8 CuM RMC
GVW (kg)	25500			
Wheel Base (mm)	4000			
Over All vehicle Length (CBC) (mm)	6245	6245	6245	6798
Over All vehicle Length (FBT) (mm)	6245	7180	7660	8495
Max Width (mm)	2479		2600	
Ground Clearance RA (mm) in Unladen	285			
Engine	VDEX8 EURO-V			
Max. Power	330HP @ 2200 RPM			
Max. Torque	1200 Nm @ 1200 - 1600 RPM			
Gear Box	ET140S9 9 Speed Gearbox			
Clutch	430Dia. Booster Assisted, Pull Type			
Rare Axle Ratio (FDR)	4.8			
TCD	14.5m			
Front Suspension	Parabolic Spring with Hyd. typ. double acting telescopic FR Shock Absorber			
Rear Suspension	Bogie Suspension			
Tire Size	315/80R22.5			
Cabin Type	Day cabin with integrated foot step			
HVAC / Blower	HVAC			
Brakes	Drum Brake at front & Rear			
Service	S-Cam fully Air Brakes			
ABS	Yes			
Parking	Yes			
Electrical System	24V			
Battery	2 x 12V - 120 Ah			
Fuel Tank Size	220L			
Gradeability (%)	70%			
Max Speed (Kmph)	88			

PRO 6025T LINE DIAGRAMS

Pro_6025T_LHD_CBC Euro-5

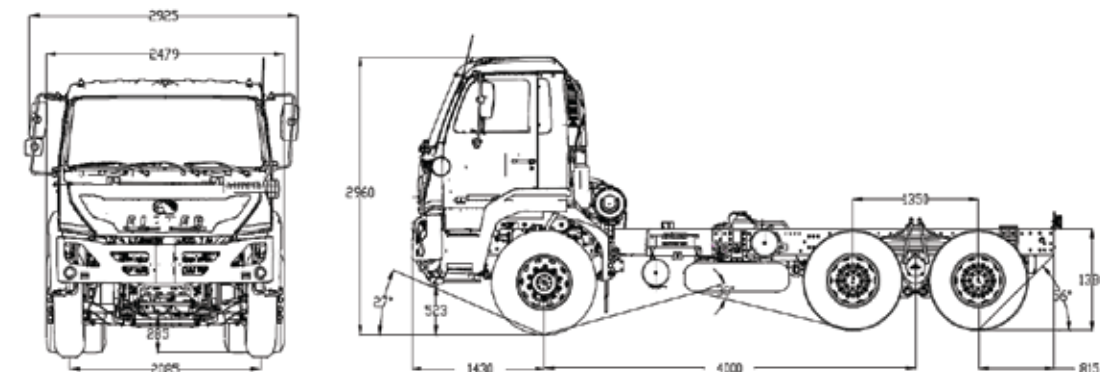

Pro 6025T-14CUM RB Euro 5

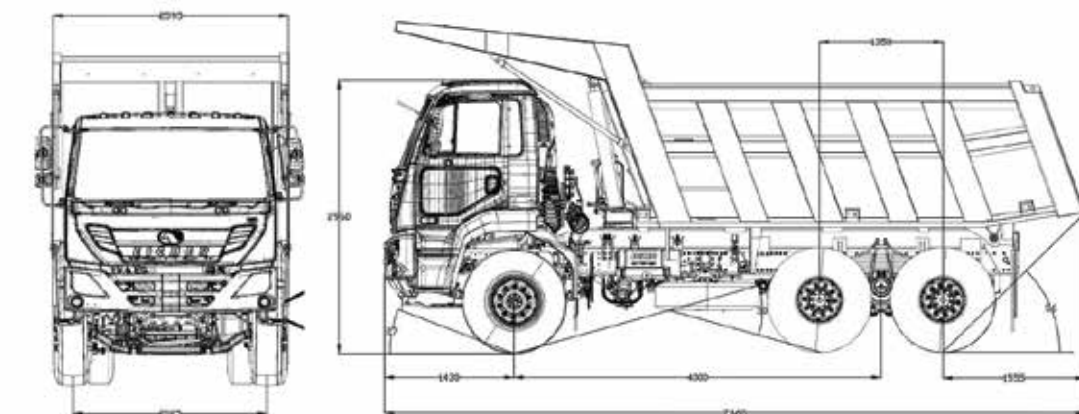

Pro 6025T-Euro 5 16CUM BB

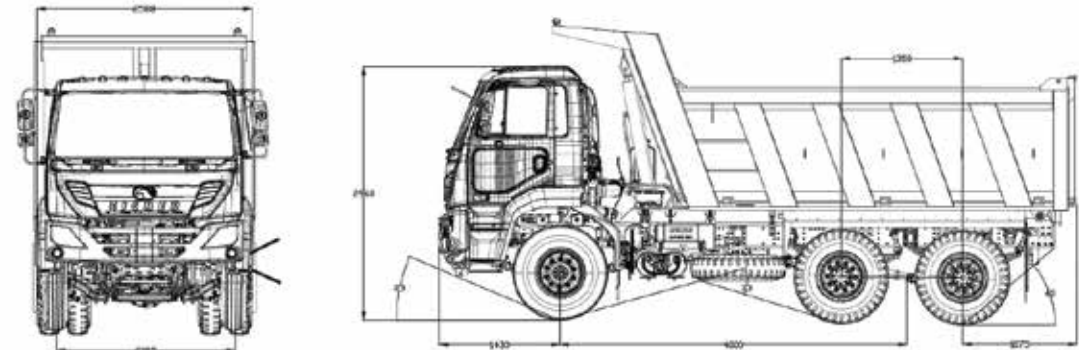

EICHER NETWORK

AFTERMARKET ASSURANCE

The point of sale is just the beginning of relationship, which is a commitment to partner the customer right through the entire life cycle of the vehicle.

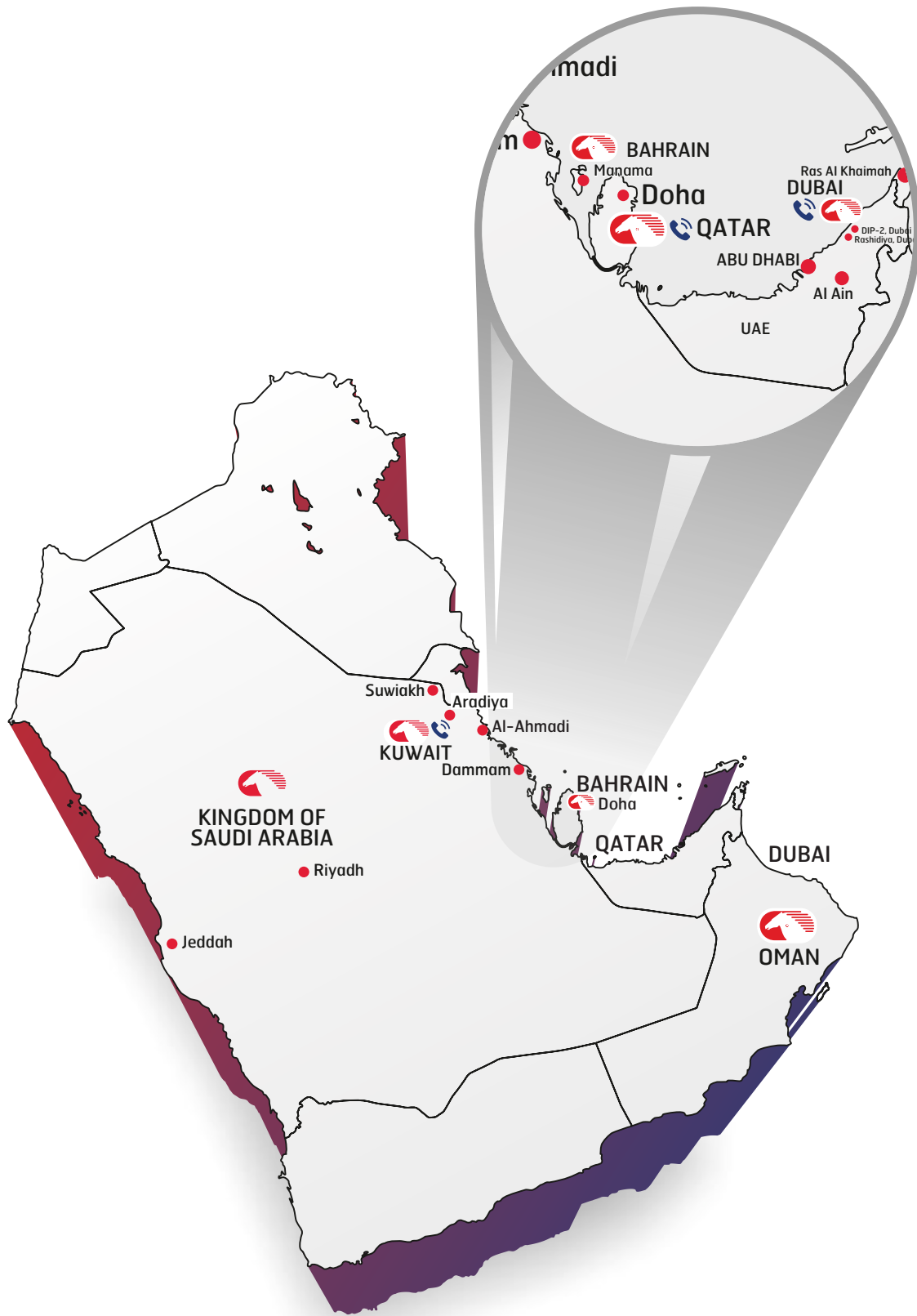

SERVICE ASSURANCE

- **COUNTRYWIDE NETWORK**
Eicher promises to deliver customer service with unmatched reliability & quality of repairs through our country's dealer network.
- **TRAINED WORKFORCE**
To maintain the service quality standards, the workshop teams are trained and certified by Eicher for diagnostics skills and exhaustive knowledge of all our products.
- **STATE-OF-THE-ART WORKSHOP**
Workshops are equipped with all modern equipments for quick service and comprehensive diagnostic system.



EICHER GENUINE PARTS ASSURANCE

- Eicher Genuine Parts are engineered specifically for your vehicle.
- Eicher Genuine Parts come up with full customer satisfaction by its unique features and reliable technology.
- Eicher Genuine Parts' high standards of design, manufacturing & stringent quality checks ensure the very best fit and finish along with performance & reliability.



EICHER ON ROAD SERVICE

- Eicher dealers are equipped with mobile service vans to ensure quick response.
- 24x7 Eicher call center to support operator in case vehicle stands immobilized enroute.
- Fully equipped dealer team ensures quick resolution by enroute breakdown assistance.



EICHER UPTIME

Eicher has taken a step towards achieving Superior Uptime with a responsive attitude, that will set us apart and create a differentiated experience for our customers.

