

## MIDDLE EAST NETWORK

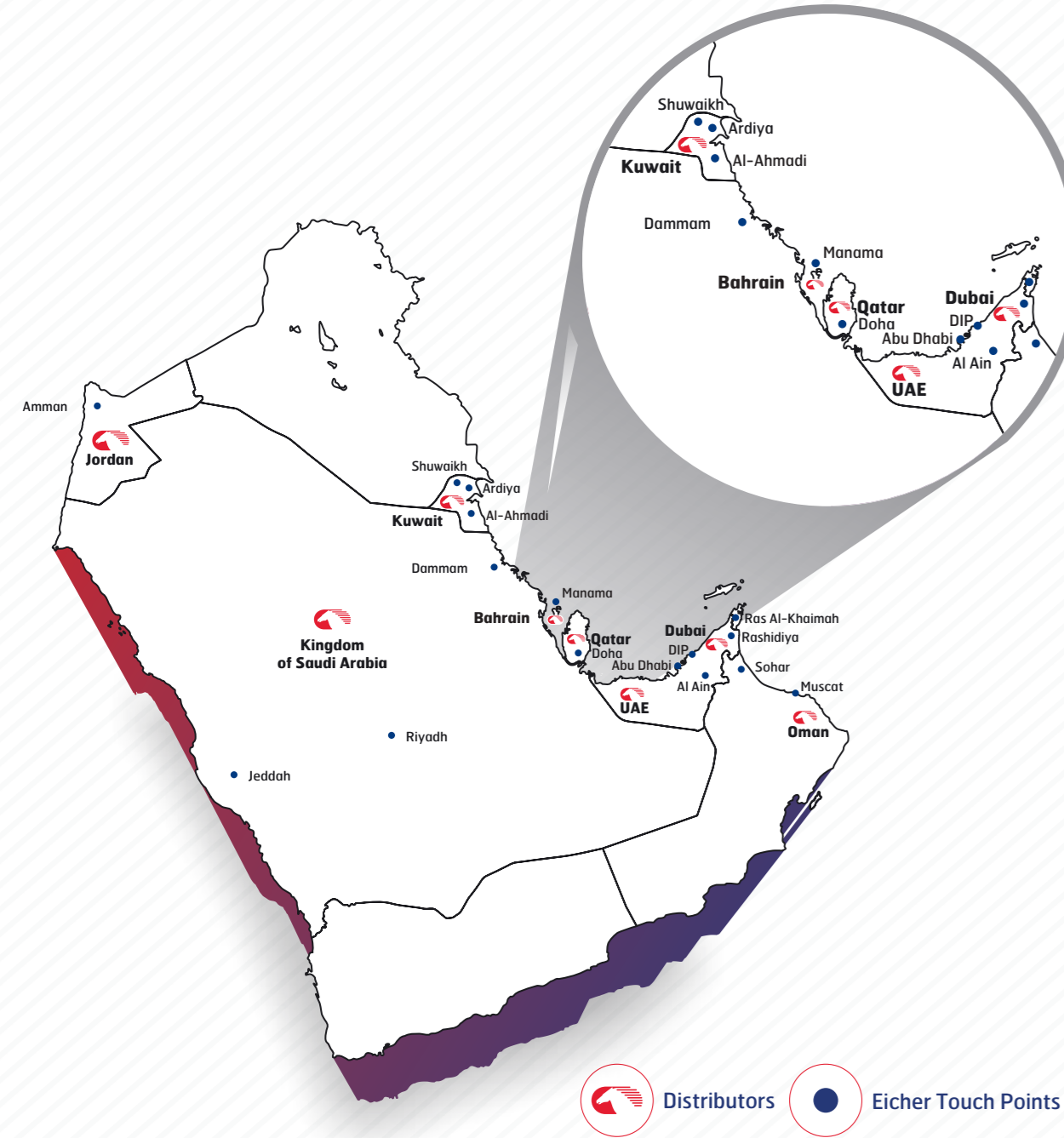

## AFTER MARKET ASSURANCE

The point of sale is just the beginning of the relationship, which is a commitment to partner with the customer right through the entire life cycle of the vehicle.

### SERVICE ASSURANCE

#### COUNTRYWIDE NETWORK

Eicher promises to deliver customer service with unmatched reliability and quality of repairs through our country's dealer network.

#### TRAINED WORKFORCE

To maintain service quality standards, the workshop teams are trained and certified by Eicher for diagnostic skills and exhaustive knowledge of all our products.

#### STATE-OF-THE-ART WORKSHOP

Workshops are equipped with modern equipment for quick service and a comprehensive diagnostic system.



### PARTS ASSURANCE

#### PARTS AVAILABILITY

Eicher Parts Distributors ensures speedy parts supply and minimum delays in delivery to our customers.

#### PARTS WARRANTY

With a vision to ensure 100% customer satisfaction, Eicher extends a warranty along with Eicher Genuine Parts through its distributors.

#### SUPPORT AGGREGATORS

To ensure higher uptime for vehicles, Eicher workshops are equipped with support aggregates.



### EICHER ON ROADS SERVICE

Eicher dealers are equipped with Mobile Service Vans to ensure quick response.

24x7 Eicher call center to support the operator in case the vehicle stands immobilised enroute.

Fully-equipped dealer team ensures quick resolution by providing breakdown assistance enroute.



### SPECIFICATIONS Eicher Pro 2095XP

GVW (kg)	10000
Wheelbase (mm)	4300
Body Type	CBC
Front overhang (mm)	1300
Rear Overhang (CBC) (mm)	2266
Cargo Body Length (ft)	19
Engine Type	E494 EURO IV
Max. Power	150 HP @ 2800 rpm
Max. Torque	490 Nm
Clutch Type	Push type
Gearbox	ET40S6
Rear Axle	Fully floating banjo type
Chassis Type	Straight Frame
Suspension	Front - Semi Elliptical with Shock Absorber Rear - Semi - elliptical with Helper spring + Shock Absorber
Steering	Hydraulic power steering, tilt and telescopic
TCD -calculated (m)	16.9
Gradeability (%)	33
Max. Speed (kmph)	101
Fuel Tank (L)	190
Battery	24V - 75A
Tyre	235/75R17.5

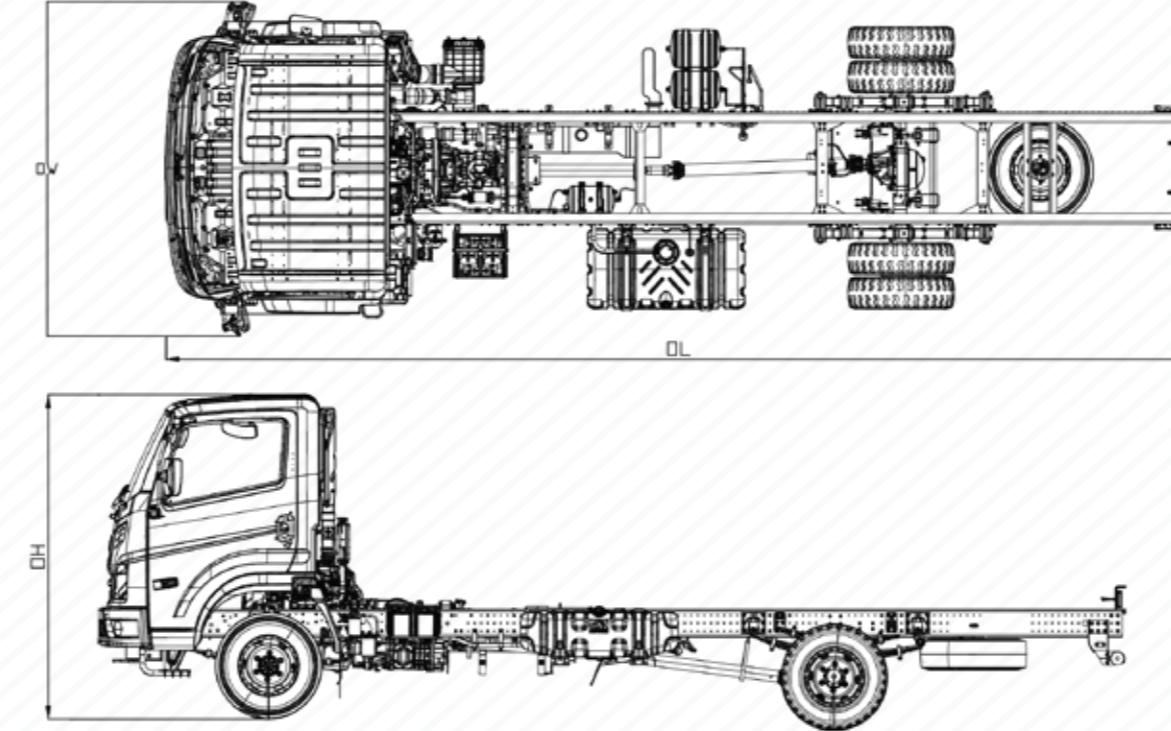

Vehicle Model	Wheelbase (WB) mm	Overall Length (OL) mm	Overall Width (OW) mm	Overall Height (OH) mm
Pro Pro 2095 XP	4300	7820	2545	2335



Market Load



Agriculture



Reefer/Chiller



Cylinder Distribution



FMCG



Furniture



Bottle Carrier



Bakery & Bread



Recovery Van

**VE COMMERCIAL VEHICLES**  
A VOLVO GROUP AND EICHER MOTORS JOINT VENTURE  
eichertrucksandbuses.com, Eicher Care: 1800 102 3531

Authorized Distributor

CORPORATE ADDRESS  
Eicher Trucks & Buses  
#96, Sector - 32, Gurgaon  
122001, Haryana, India.

Caution: \*Do not weld or drill on chassis frame. \*Accessories and features shown in pictures or elsewhere may not constitute standard fitment. \*Weight mentioned is for standard configuration with standard body sizes and will change due to optional fitments. \*As a result of continuous research and innovation carried out, specifications are merely indicative and are subject to change without notice.



# THE SMART PERFORMER

## Eicher Pro 2095XP The 10T GVW Truck

Powered by

# EUTECH 5



# EUTECH 5

www.eichertrucksandbuses.com

## EICHER'S EURO-V STORY

Eicher is creating a new benchmark in the commercial vehicle industry with a revolutionary Euro V solution that combines global technology with innovative support services. This solution doesn't just make your vehicle Euro V compliant but ensures higher productivity of the truck and profitability of your business.

### Euro V expertise

VECV has been manufacturing & supplying Euro V engines to Volvo Group since 2018. The engine has been tested for more than 10,00,000 Kms

### Superior Uptime

With the new Euro V technology, Eicher Trucks are now designed to deliver superior uptime, ensuring timely deliveries, maximum fleet productivity, and consistent profitability on every trip

### Efficient EATS and Engine Technology

With the improved Euro V technology, Our EATS system will now treat and control pollutants like NOx, CO, HC and PM more efficiently, through different chemical processes.

### Superior Reliability and Durability

With the Euro V technology, our buses are equipped with superior Reliability with stronger and improved aggregates.



Eicher Pro 2095XP is a new generation 10 tonne GVW truck, designed and developed through Volvo Group's world-class leading processes. Eicher Pro 2095XP gives you unmatched performance with next-gen smart features that take care of your daily transportation needs.

## PRO 2000 SERIES

A new generation range of Eicher trucks from 6.25T to 10T with tilted cabin feature that offers enhanced driver comfort, safety and reliability through Volvo Group's expertise.



## More km per litre

The new Eicher Pro 2095XP is built to deliver best-in-class fuel efficiency, thereby reducing the overall operational cost and increasing profitability.

With the proven E494 engine and EMS, Pro 2095XP is capable of delivering flat torque over a wide RPM range which prevents frequent gear shifts.



## Stay ahead with next-gen features

- » MBooster+ helps to save fuel on different payload selections
- » Smart Fuel Coaching along with dynamic Green Band Zones is the driver's real-time coach
- » Cruise Control provides a fatigue-free driving experience



## Stay ahead with the safest and most reliable truck

- » Stronger and sturdier dual panel cabin
- » Anti-roll bars for safer turns on sharp bends
- » Steering mounted controls
- » Infotainment system
- » Sun Visor for both- Driver & Co-driver
- » Central locking system (Manual)
- » Headlamp with DRL for enhanced visibility
- » 3 point ELR seat belt for driver safety



## More comfort. Longer drive.

- » 8-degree cooler and lowest noise cabin
- » Walk through cabin for more area
- » Tilt & telescopic steering for better ergonomics
- » 4 stage speed blower
- » Adjustable headrest for driver comfort
- » Inside footrest for dust and water protection

