

## Model Eicher Pro 6031T

GVW (kg)	31000
Engine	VEDX8, BS-III
Max. Power	280 hp @ 2200 rpm
Max. Torque	1050 Nm @ 1000-1800 rpm
Clutch (mm)	430 mm, Pull Type, Booster Actuated
Gearbox	ET140S9
Front Axle	Forged reverse Elliot type
Rear Axle	Heavy-duty single reduction tandem axle
Rear Axle Ratio	5.29
Chassis Dimensions (mm)	300x90x8 with 5 mm full length inner liner
Service Brake	Full Air S-Cam Dual Line
Parking Brake	Pneumatically operated hand-control valve
Front Suspension	Parabolic
Rear Suspension	Bogie
Cabin	Day cabin
Steering	Tilt and telescopic power steering
Tyres	11x20 (Nylon)
Wheel Rims & Tyres	7.5x20 (Nylon)
Fuel Tank (Litres)	315
Battery	24V 120 Ah
Wheelbase (mm)	5285
Turing Circle Diameter (m)	18.6
Gradeability (%)	47% Crawler
Ground Clearance (mm)	252
Body Variants (mm)	20 Cu.M (Box), 23 Cu.M (Box)
Standard Features	Fuel Coaching, Cruise Control

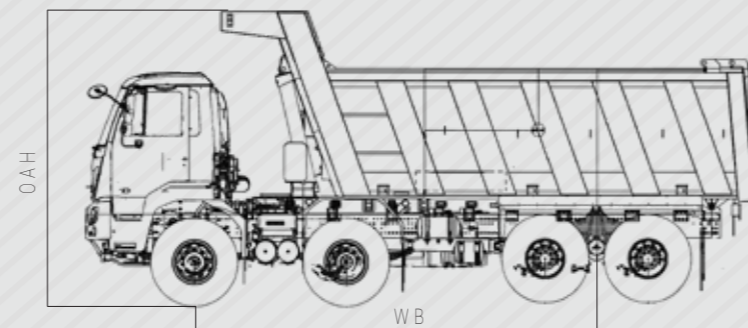
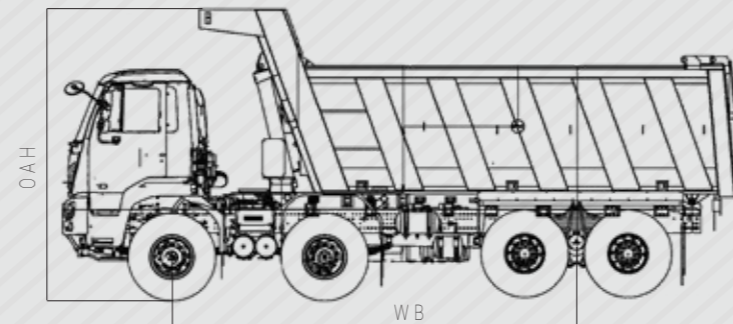
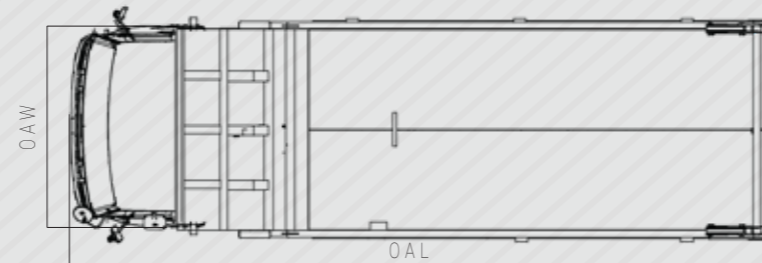

Vehicle Model	Wheelbase (mm)	Overall Length (OAL) mm	Overall Width (OAW) mm	Overall Height (OAH) mm
Pro 6031T 20 Cu.M & 23 Cu.M	5285	8888	2600	3675

Caution: \*Do not weld or drill on chassis frame. \*Accessories, colours and features shown in pictures or elsewhere may not constitute standard fitment. \*Weight mentioned is for standard configuration with standard body sizes and will change due to optional fitments. \*As a result of continuous research and innovation carried out, specifications are merely indicative and are subject to change without notice.

### EICHER TRUCKS AND BUSES

VE Commercial Vehicles Ltd.  
#96, Institutional Area,  
3<sup>rd</sup> Floor, Sector 32  
Gurgaon-122001, Haryana.



A VOLVO GROUP AND EICHER MOTORS JOINT VENTURE

TRUCKS AND BUSES



# Do More.

## Eicher Pro 6031T

### The 31 Tonne GVW Tipper

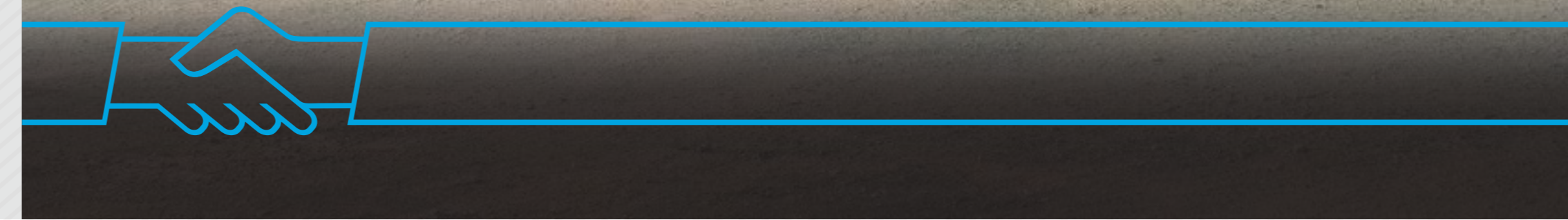

## More Tonnes per Litre.

The new Eicher Pro 6031T is built to deliver best-in-class fuel efficiency thereby **reducing the operational costs**.

The proven **VEDX8** engine clubbed with Volvo Group's EMS, delivers **high peak torque over a wide range of rpm**, ensuring that Pro 6031T makes the most out of every drop of fuel.

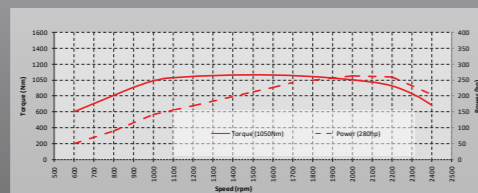

FIE System

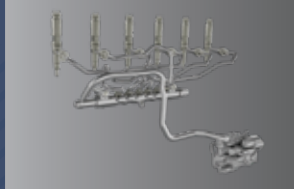

Volvo Group's EMS



ESS Compressor



- » Next-gen VEDX8 common rail engine
- » Optimum engine design with wider flat torque curve 1000-1800 rpm
- » Higher power of 280 hp @ lower 2200 rpm
- » Aerodynamic cabin to reduce air drag
- » First-in-industry **Fuel Coaching** for improved driver performance

## More Trips. Faster Turnaround.

Pro 6031T is made with a robust and optimized driveline which delivers **high torque at wheels** to carry higher loads in the toughest of terrains. **Higher power-to-weight ratio** provides higher pulling power and superior gradeability leading to **faster turnaround and more trips**.

- » High peak torque of 1050 Nm
- » High gradeability - 47% and Low TCD - 18.6 M
- » High torque at wheels with 5.29 FDR
- » Higher power-to-weight ratio
- » Heavy-duty bogie suspension
- » Inter-axle differential lock
- » Ergonomically designed cabin for driver productivity

Parabolic Suspension

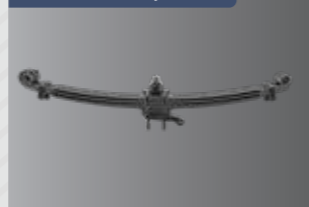

Bogie Suspension



Maximum Gradeability 47%

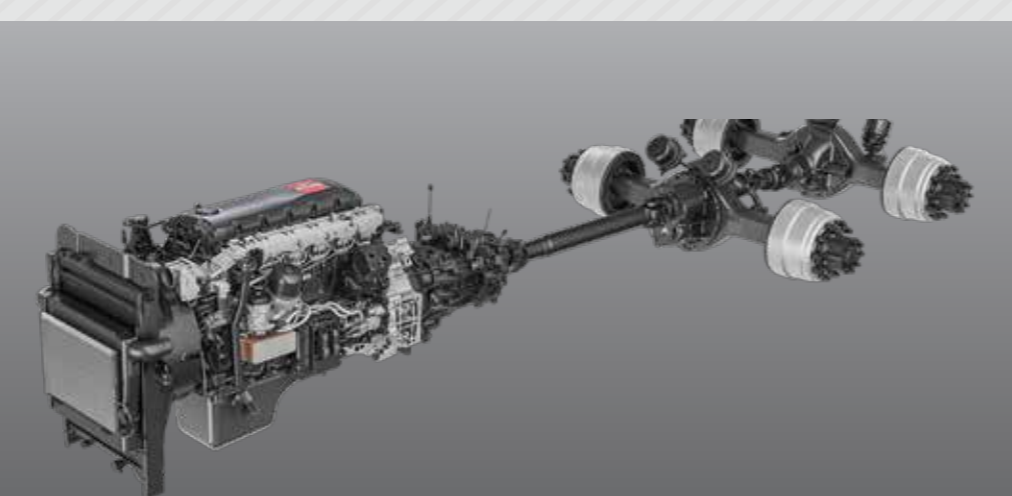

## Superior Uptime.

In construction & mining, **Uptime is everything** and Pro 6031T is **designed to ensure optimum utilization of all your assets**. Along with the fully equipped service network, Pro 6031T delivers superior uptime ensuring the operations never stop.



Clutch Wear Indicator



ET140 9-speed Gearbox

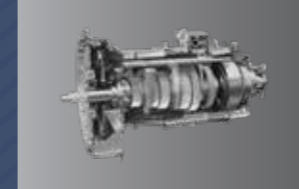

Bigger Crown Wheel

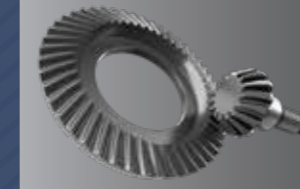

- » Reliable VEDX8 engine with longer L10 Life
- » Reliable and robust aggregates for higher uptime
- » High-strength DOMEX chassis
- » Engine Protection System
- » On-board diagnostics
- » Designed for easy maintenance

## More Comfort. Enhanced Safety.

Pro 6031T cabin has been designed keeping in mind the harsh conditions the drivers have to operate in, in construction and mining applications. The **global cabin** provides a **comfortable workspace** that ensures the drivers are not only comfortable, but alert for longer hours.

- » HVAC (optional) for better comfort
- » Parabolic suspension at front
- » Tilt and telescopic power steering
- » Mechanically suspended driver seat
- » Intelligent Driver Information System (IDIS) & Cruise Control
- » All-round mirrors and engine brake for enhanced safety

IDIS



Mechanically Suspended Driver Seat



Tilt and Telescopic Power Steering

